

Tapping Center

# VTX Series



**Tongtai Tongtai Machine & Tool Co., Ltd.**

**Headquarters**

No.3, Luke 3rd Rd., Luzhu Dist., Kaohsiung City 82151, Taiwan  
TEL : 886-7-9761588 FAX : 886-7-9761589  
www.tongtai.com.tw

Taoyuan Branch	TEL : +886-3-4551399	FAX : +886-3-4559730
Taichung Branch	TEL : +886-4-23589600	FAX : +886-4-23589993
Japan Branch	TEL : +81-047-712-0835	FAX : +81-047-712-0870
Europe Branch	TEL : +31-161-454639	
Malaysia Branch	TEL : +603-78597113	FAX : +603-78597115
Vietnam Branch	TEL : +84-24-62766090	
Thailand Branch	TEL : +66-2-3164708-10	FAX : +66-2-3164711
Indonesia Office	TEL : +62-21-45850875	FAX : +62-21-45850876

**Members of TTGroup**

<b>Honor Seiki Co., Ltd.</b> TEL : 886-7-9759888 FAX : 886-7-9759999 www.honorseiki.com.tw	<b>Asia Pacific Elite Corp.</b> TEL : 886-4-23589313 FAX : 886-4-23588913 www.apecnc.com	<b>Quick-Tech Machinery Co., Ltd.</b> TEL : 886-6-3841155 FAX : 886-6-3841177 www.quicktech.com.tw	<b>PCI-SCEMM</b> TEL : 33-4-77426161 FAX : 33-4-77426023 www.pci.fr	<b>ANGER Machining GmbH</b> TEL : 43-7229-71041-0 FAX : 43-7229-71041-199 www.anger-machining.com
---	---	---	--	--

MEMBER OF  
**TTGROUP**



Official Website Global Network

**China Operation Center**

**Shuzhou Tong-yu Machine & Tool Co., Ltd.**  
No.555 Huahong Rd., Economic Development Zone of Wujiang,  
Suzhou City, Jiangsu Province, China  
TEL : 86-512-63430168 FAX : 86-512-63431622  
E-mail : sales@tong-yu.com.cn  
www.tongtai.com.tw/cn

Wuhan Branch	TEL : +86-27-84586587
Chongqing Branch	TEL : +86-23-67865925 FAX : +86-23-67867717
Guandong Branch	TEL : +86-769-81158198 FAX : +86-769-81158108
Tianjin Branch	TEL : +86-22-24417640 FAX : +86-22-24416738
Shanghai Office	TEL : +86-21-24208138 FAX : +86-21-34073262
Shenyang Office	TEL : +86-24-24142968 FAX : +86-24-24115782

VTX Series 2023.10.13 © All the specifications in the brochure are subject to change without prior notice.

MEMBER OF  
**TTGROUP**

www.tongtai.com.tw

# VTX Series



- **VTX Series high torque type** not only provides the machining torque equal to a medium-sized machining center, but also keeps its originally outstanding rapid traverse performance.
- **VTX Series high efficiency type** has outstanding spindle acceleration/deceleration performance, which provides fast spindle orientation to the tool changing point and dramatically saves cycle time.
- VTX series has high production efficiency with compact footprint. That improves production capacity in per unit of space.
- Compared with conventional belt-driven spindles, VTX series is standardly equipped with a direct-drive spindle for better rigid tapping performances. Furthermore, it solves the problem of short usage life in the belts.
- Standardly equipped with a servo-driven tool magazine, which is able to save idle time obviously.
- Adopts A shape column design and is standardly equipped with roller type linear guideway, ensuring the dynamic stability under the rapid traverse 60m/min with the 1.2G accelerate force.



### Main specifications

Item	Unit	VTX-511	VTX-711	VTX-10
X/Y/Z axis travel	mm	510/400/300	710/400/300	1,000/500/300
Spindle (Direct-drive type)	rpm	12,000		
Max tapping speed	rpm	6,000		
Rapid traverse	m/min	60/60/60		50/50/56
Cutting feedrate	m/min	1-20,000		1-10,000

CONTENTS

- 03 Main structure
- 04 Machining capacity / Spindle output and torque chart
- 05 ATC
- 06 Safety / Operation / Peripheral accessories
- 07 FANUC controller specification
- 08 MITSUBISHI controller specification
- 09 Accessories / Machine dimensions
- 09 Specifications

# Main structure

## BBT direct-drive spindle (Std.)

Machine structure is optimized by Finite Element Analysis (FEA) and the anti-deforming capacity on X axis is improved by 25%, which brings excellent machining precision and extends tool life.

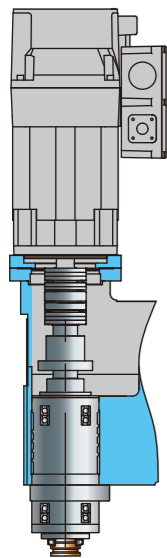

**Wide column design**  
The rigidity of the X axis direction increases by 25%

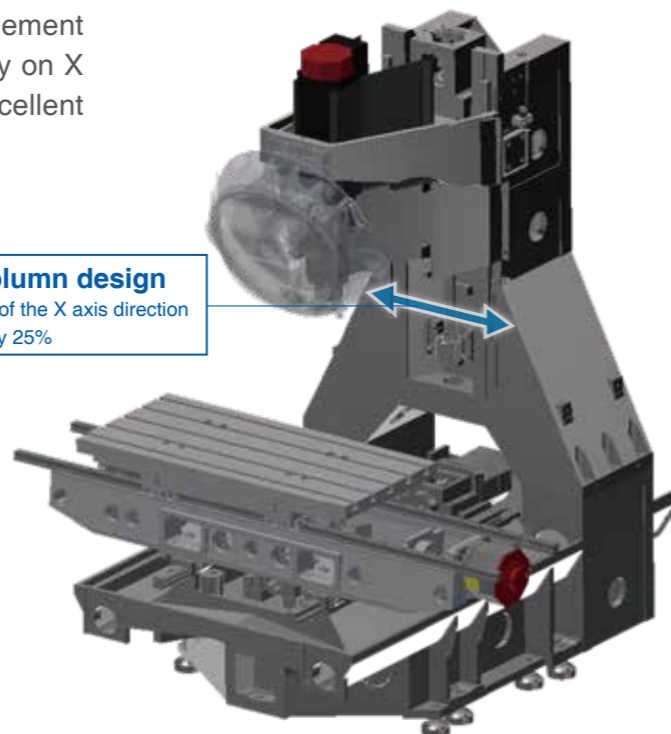

※This image is the structural diagram of VTX-10.

- Spindle with long-neck design prevents the interferences happening during machining.
- For providing high radial rigidity, the spindle adopts large-sized steel ball bearings and has the best span column design.

## Roller type linear guideway

Adopts roller type linear guideway designed with DB type, the rigidity is improved and has the capacity to complete heavy duty machining works.

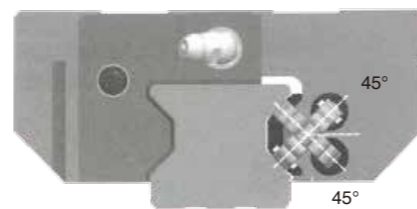

## Table size

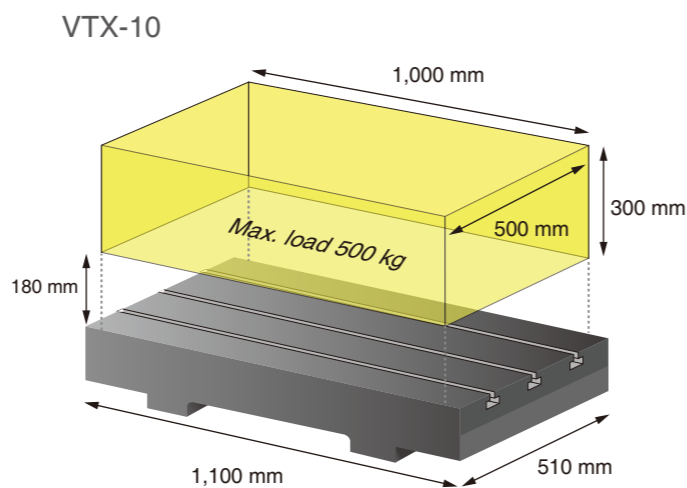
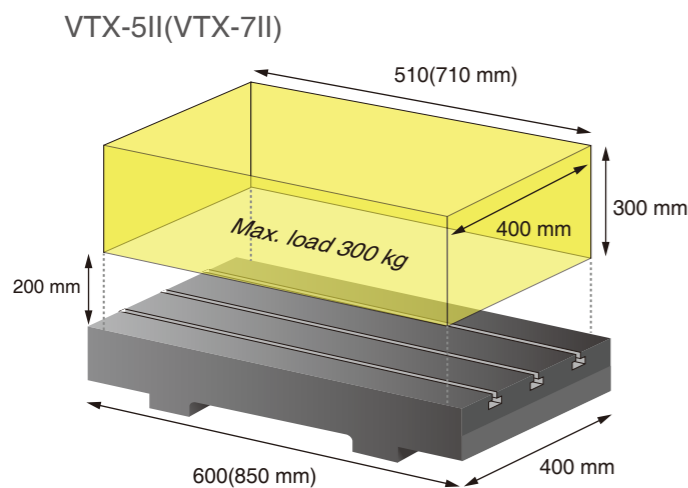

# Machining capacity / Spindle output and torque chart

## Measured value of machining capacity

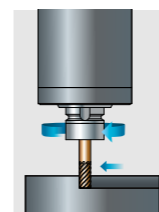

End mill	Ø20 mm	
Spindle motor	High torque type	High efficiency type
Material	S45C	S45C
Cutting depth/width	30/4 mm	20/2 mm
Spindle speed	3,182 rpm	1,592 rpm
Feedrate	1,273 mm/min	1,273 mm/min
Material removal rate	153 cm <sup>3</sup> /min	51 cm <sup>3</sup> /min

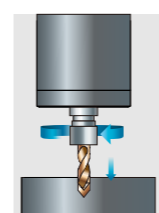

Drill	Ø30 mm	Ø16 mm
Spindle motor	High torque type	High efficiency type
Material	S45C	S45C
Spindle speed	424 rpm	580 rpm
Feedrate	84 mm/min	60 mm/min

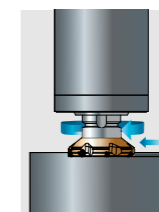

Face mill	Ø80 mm	
Spindle motor	High torque type	High efficiency type
Material	S45C	S45C
Cutting depth/width	2/65 mm	1.8/65 mm
Spindle speed	915 rpm	1,200 rpm
Feedrate	1,372 mm/min	780 mm/min
Material removal rate	178 cm <sup>3</sup> /min	91 cm <sup>3</sup> /min

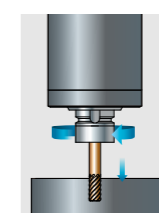

Tap	High torque type	High efficiency type
Spindle motor	High torque type	High efficiency type
Material	S45C	S45C
Max. M hole	M24xP3.0	M16xP2.0
Min. M hole	M2xP0.5	M2xP0.5

## High torque type

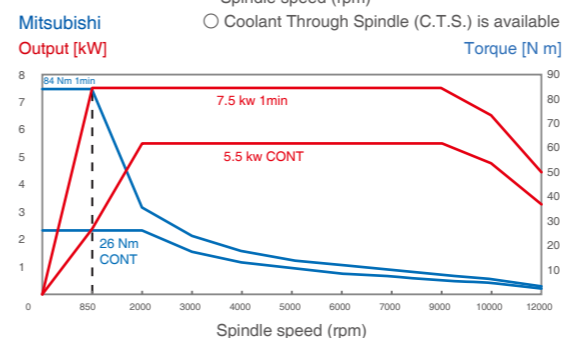
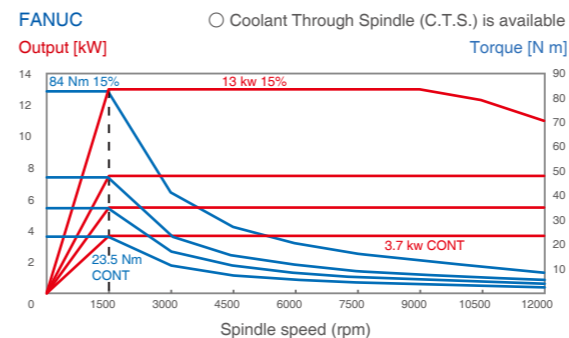

## High efficiency type

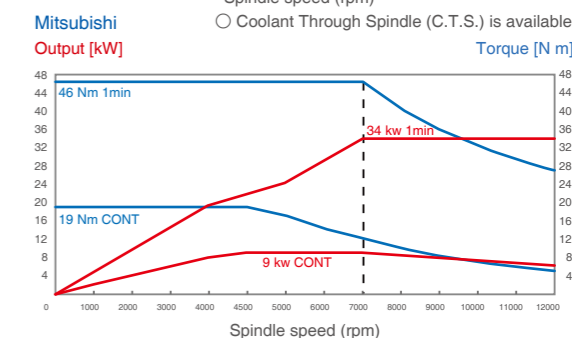
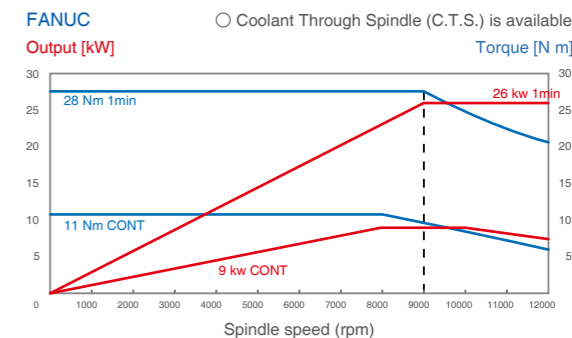

# Automatic tool changer (ATC)

## Servo-driven tool magazine

New low backlash tool changing system performs fast and stable tool changing with low noise.

T to T time	1.2 sec
Index time (opposite tool)	1.1 sec
Tool capacity	21 pcs
Max. tool weight	3 kg
Max. tool length	200 mm
Max. tool diameter	80 mm



**Chip to Chip = 1.7 sec**

※This test data belongs to VTX-10 high efficiency type. The time of Chip to Chip of the high torque type is 1.85 seconds.  
 ※The test was performed by the regulations of JIS B6013.

## Clamping error inspection function

This function avoids tool damage caused by human operating errors and guarantees machining quality.



Due to the incorrect tool placement, the drive block doesn't into the drive slot of the holder.



Controller displays alarming messages when the tool doesn't clamp completely.

# Safety/Operation/Peripheral accessories

## Enhance your productivity

The time of spindle acceleration in the VTX Series high efficiency type is only the one-third to the high torque type. If you pursue high productivity, the high efficiency type is recommended.

(CASE) Processing schedule of customer's workpiece

- Center drill X5
- D3.6 drill & M4 tapping X2
- D5.2 drill & M6 tapping X2
- D14.5 drill & M16 tapping X1

8 hours continuous production :

High efficiency type

652

11%

High torque type

587

300 420 540 660  
Volume of production (pcs)

## Safety

The safety window adopts the PC board. It's capacity of impact strength is similar to tempered glass and also improves the operation safety.



## Interior flushing system

Standardly equipped with the large flow machine bed flushing system to avoid chip accumulation in the machine.

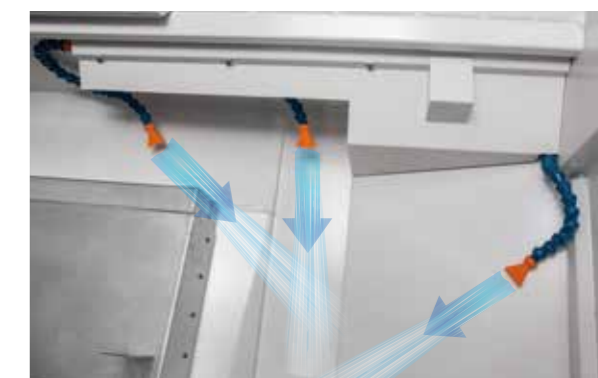

## Taper shank cleaning (opt.)

Filtered high pressure water washes the taper shank during tool changing. It prevents attached chips from influencing the clamping precision.



## Easy coolant tank cleaning

Conventionally, the operator should remove the chip tray before the coolant tank cleaning. The bracket design of VTX can easily hold up the chip tray facilitating users to clean the bottom of the tank.



# FANUC controller specification

## Controlled axis

Function	Specification	Std.	Opt.
Controlled axis	3 axes(X, Y, Z)	●	
Number of axis expansion	5 axes(4+1)	●	
Simultaneously controlled axes	4 axes	●	
Inch/metric conversion	(G20/G21)	●	
Increment system	0.0001mm/0.00001"/0.0001"(IS-C)	●	
HRV3 control		●	
Interlock		●	
Machine lock		●	
Emergency stop		●	
Over travel		●	
1/2 Stored stroke check 1/2		●	
Position switch		●	

## Feed function

Function	Specification	Std.	Opt.
Rapid traverse rate	F0,25%,50%,100%	●	
Tangential speed constant control		●	
Cutting feedrate clamp		●	
Automatic acceleration/deceleration		●	
Rapid traverse bell-shaped acceleration/deceleration		●	
Linear acceleration/deceleration after cutting feed interpolation		●	
Bell-shape acceleration/deceleration after cutting feed interpolation		●	
Smart overlap	G93	●	
Inverse time feed	0-150(%)	●	
Feedrate override	0-1260(mm/min)	●	
Jog override		●	
One-digit F code feed		●	
Rigid tapping bell-shaped acceleration/deceleration		●	

## Interpolation functions

Function	Specification	Std.	Opt.
Linear interpolation	G01	●	
Circular interpolation	G02/G03	●	
Cylindrical interpolation	Rotating axis is required	●	
Helical interpolation		●	
Continuous threading		●	
Skip	G31	●	
High speed skip	Input signals is 4 points	●	
Nano interpolation		●	
Fine Surface Machining	Look-ahead block no. is Max. 200 • AI contour control II • Smooth tolerance control • Jerk control • Machining quality level adjustment function	●	

## Tool function/ Tool compensation

Function	Specification	Std.	Opt.
Tool function	T8 digit	●	
Tool length offset	G43/G44/G49	●	
Tool radius compensation	G40-G42	●	
Tool offset	G45-G48	●	
Tool offset pairs	400-pairs	●	
Tool life management		●	
C Tool offset memory C	Geometry (H), Wear (H)/ Geometry (D), Wear (D)	●	

## Operation

Function	Specification	Std.	Opt.
Automatic operation		●	
DNC operation	Reader/Puncher interface is required	●	
DNC operation with CF card	M198 (PCMCIA card is required)	●	
Buffer register		●	
Single block		●	
Manual handle function	1 unit/each path	●	
Manual handle feed rate	X1,X10,X100	●	
Jog		●	
Reference position return	G28,G30	●	
Sequence number comparison and stop		●	
Program restart		●	

Retraction for rigid tapping		●	
M99		●	

## Auxiliary/Spindle speed function

Function	Specification	Std.	Opt.
Auxiliary function		●	
High speed M/S/T interface	Standard	●	
Spindle speed function	S5 digit, binary output	●	
Spindle override	50-120%	●	
1st spindle orientation	M19	●	
Rigid tap	M29	●	
Auto Power Off	M30		○

## Program input

Function	Specification	Std.	Opt.
EIA/ISO		●	
Parity check		●	
Control in/out		●	
Optional block skip	1	●	
Max. programmable dimension	±9 digit	●	
Program file name	32 characters	●	
Sequence number	N8 digit	●	
Sub program call	10 folds nested	●	
M00,M01/M30	M00/M01/M02/M30	●	
Reset		●	
Programmable data input	G10	●	
Custom macro B		●	
Addition of custom common variables	#100-#199/#500-#999	●	
Absolute/incremental programming		●	
Decimal point programming/ pocket calculator type decimal point programming		●	
Input unit 10 time multiply		●	
Diameter/Radius programming	G17/G18/G19	●	
Plane selection		●	
Rotary axis designation		●	
Rotary axis roll-over	G15/G16	●	
Polar coordinate command		●	
Automatic coordinate system setting		●	
Workpiece coordinate system preset	G52-G59	●	
Workpiece coordinate system	48 pairs	●	
Workpiece coordinate system	G68/G69	●	
Coordinate system rotation	G80-G89	●	
Canned cycle for drilling		●	
Small-hole peck drilling cycle		●	
Peck Rigid Tapping Cycle		●	
Chamfering/Corner R		●	
Circular interpolation by R programming	G62	●	
Automatic corner override		●	
Scaling	G50.1/G51.1	●	
Programmable mirror image		●	

## Data input/output

Function	Specification	Std.	Opt.
RS-232C interface		●	
PCMCIA card interface		●	
USB interface	Data access only	●	
Embedded Ethernet		●	
Fast Ethernet	S707		○
Data Server	CF card 4GB or more		○
PROFIBUS			○

## Editing operation

Function	Specification	Std.	Opt.
Part program storage size	2M byte(5120M)	●	
Number of registerable programs	1,000 programs	●	

## Setting and display

Function	Specification	Std.	Opt.
10.4" color LCD		●	
Run hour and parts count display		●	
Dynamic graphic display function		●	
Periodic maintenance screen		●	

# MITSUBISHI controller specification

## CPU Processor, control axes and related specification

Function	Specification	Std.	Opt.
Max. control axis (Max. NC+ SP+ PLC axis)	11	●	
Max. number of simultaneous contouring control axes(in one system)	4	●	
Max. number of part systems	2	●	
Least control increment	1nm	●	
Max. memory capacity (1m=0.4KB)	500KB	●	
Max. sets of variable command	700	●	
Max. workpiece coordinate system selection	54 Sets	●	
Max. sets of tool compensation	400 Sets	●	
Maximal number of PLC axis	6	●	
Maximal number of NC axes	8	●	
Max. number of NC axes in a part system	8	●	

## High speed & high accuracy machining control related functions

Function	Specification	Std.	Opt.
High accuracy control(G8P1/G61.1)		●	
High speed & high accuracy machining control mode 1 (G05.1Q1)		●	
High speed & high accuracy machining control mode 2 (G05P10000)	(33.7kBPM)	●	
High speed & high accuracy machining control mode 3 (G05P20000)	(67.5kBPM)	●	
SSS control(Super Smooth Surface)	(135kBPM)	●	
Tolerance Control		●	
Spline interpolation		●	
Spline interpolation2		●	
Max. blocks in pre-read buffer	1350(G05P20000)	●	
Rapid traverse block overlap		●	
Front IC card mode (same as Data Server)	SD	●	
High-speed Program Server in NC unit(Data Server)		●	
Real time Turning		●	

## Graphic related function

Function	Specification	Std.	Opt.
3D solid graphic and program check		●	
2D graphic check and trace		●	

## Operation and programming support related functions

Function	Specification	Std.	Opt.
Workpiece position measurement (Surface/Hole/ Width/Rotation)		●	
Buffer correction		●	
Manual speed command		●	
Program restart easily after power down or tools broken		●	
Scaling (G50/G51)		●	
Coordinate rotation by G program (G68/G69) & parameter		●	
Mirror image by parameter, G code and external input		●	
Pecking Tapping Cycle/Deep-hole tapping cycle		●	
Spiral/Conical interpolation(G02.1/G03.1)		●	
Polar coordinate command(G15/G16)		●	
Polar coordinate interpolation(G12.1/G13.1)		●	
Helical interpolation(G17-19+G02/G03)		●	
Inclined surface machining(G68.2/G53.1/G53.6)		●	
GOO Feedrate Designation (F Command)		●	
Manual Speed Clamp		●	
3-dimensional Manual feed		●	
R-Nav		●	
Manual Arbitrary Reverse Run (Program Check Operation)		●	
Tool center point control	C0(Support 4 axes)	●	
Interactive Cycle Insertion	C4	●	

NC axis/PLC axis switchover	C4	●	
Fixed cycle for turning machining	C6	●	
Synchronous tapping with analog I/F spindle	D1	●	

## Maintenance & others related functions

Function	Specification	Std.	Opt.
USB memory I/F		●	
Ethernet Interface	2	●	
NC-Explorer(Data transfer tool)	Ver.C2	●	
Operation & G-Code guidance		●	
Alarm & Parameter guidance		●	
Simple programming	Navi-Mill	●	
NC data backup(Automatic & Manual)		●	
Menu selection		●	
MES Interface Library		●	
EcoMonitorLight Connection		●	
Image input I/F	C5	●	
VNC server	C6	●	

## Servo and spindle drive system

Function	Specification	Std.	Opt.
Communication type between controller and drives		●	
Encoder specification of servo motor(HG Series)	1000Kp/rev	●	
Vertical axis drop prevention while power down		●	

# Accessories/ Machine dimensions

Standard ● Optional ○

Item	Std.	Opt.
LED work light	●	
Manual pulse generator	●	
Workpiece counter	●	
Tri-color warning light	●	
Tool magazine	●	
Flushing system	●	
Spindle air-blow	●	
Interlock	●	
Coolant around spindle	●	
Spindle tool clamping detector	●	
MITSUBISHI controller function High speed & high accuracy machining control mode 3 /SSS control (Super Smooth Surface) / Tolerance Control	●	
FANUC controller function AI contour control II / Smooth tolerance control Jerk control / Machining quality level adjustment function	●	
Tool life management (controller)	●	
Controller screen 10.4"	●	
Coolant through spindle (C.T.S.)		○
Disc type oil skimmer		○
Air gun set		○
Coolant gun set		○
Automatic door		○
Oil-mist collector		○
Chip conveyor (hinge type)		○
Chip conveyor (scraper type)		○
Transformer / Stabilizer		○
Tool breakage detector / Tool measurement		○
4th axis (VTX-II Max. : Ø200mm 、 VTX-10 Max. : Ø250mm)		○
Hydraulic units and interface		○
A/C for electrical cabinet		○
CE standards		○
Automatic power off system		○
Taper shank cleaning		○
Auger-style chip conveyor		○
Rear cover		○
Extended column (VTX-II : 100,200mm 、 VTX-10 : 150mm)		○

## Machine dimensions

### VTX-II

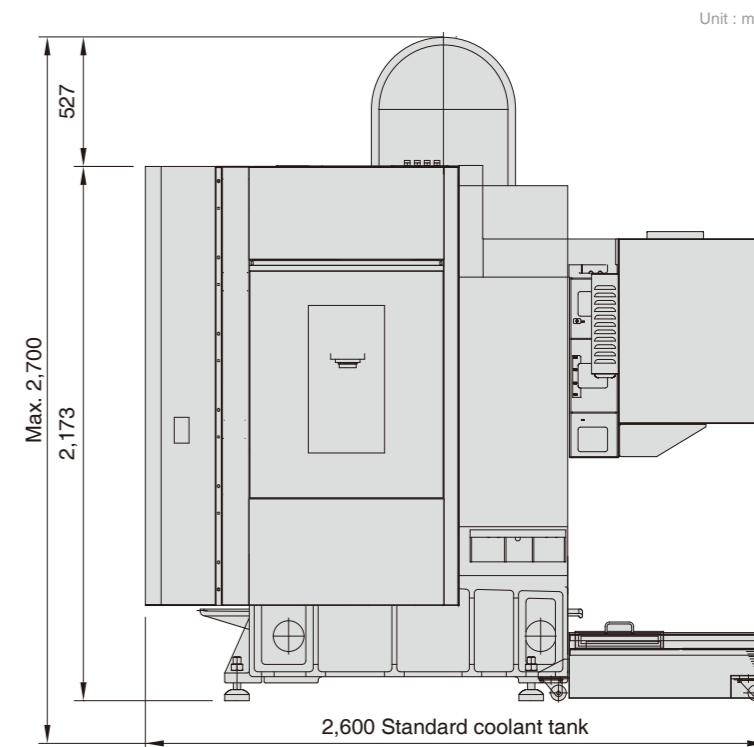
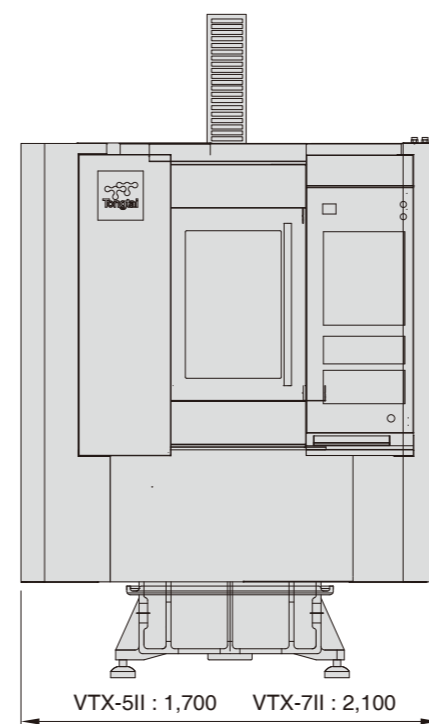

### VTX-10

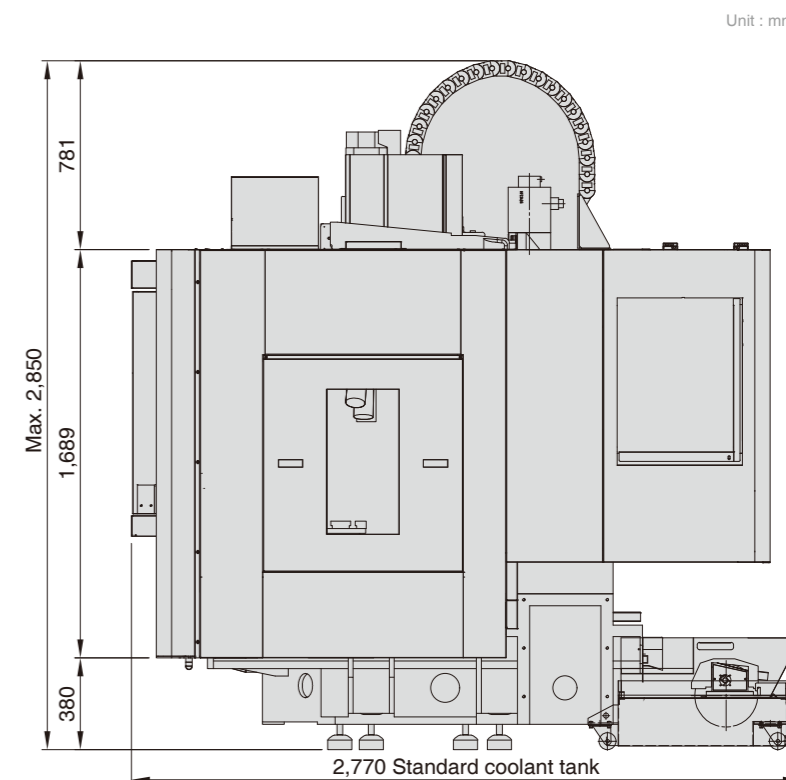
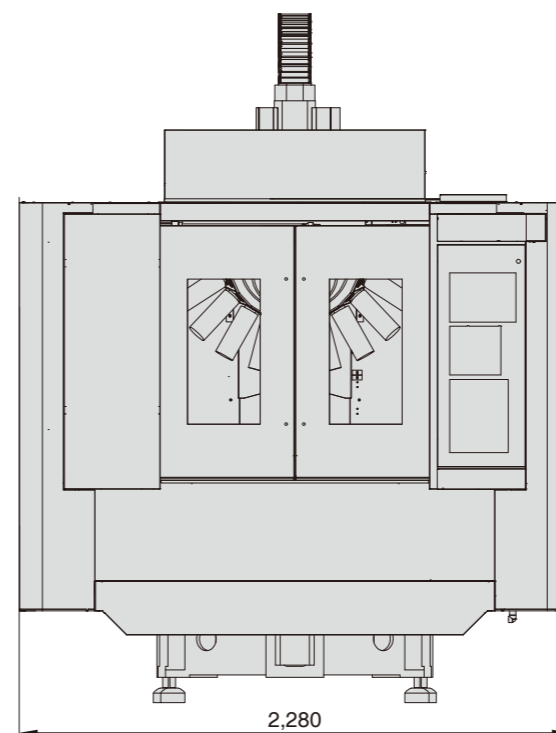

# Specifications

Item	Specification	Unit	VTX-5II	VTX-7II	VTX-10
Table	Table size (L×W)	mm	600×400	850×400	1,100×510
	Max.loading capacity	kg	300		500
	Table height from floor	mm	850		900
	T-slot (dimension x amount)	mm	18×3		18×5
Spindle	Spindle taper		7/24 Taper No. 30		
	Spindle speed	rpm	12,000		
	Max. speed of rigid tap	rpm	6,000		
Travel	X/Y/Z axis travel	mm	510/400/300	710/400/300	1,000/500/300
	Spindle nose to table	mm	200-500		180-480
Feed	X/Y/Z axis rapid traverse	m/min	60/60/60		50/50/56
	Cutting feedrate	mm/min	1-20,000		1-10,000
ATC	Tool shank		BBT-30		
	Tool capacity	pc	21		
	Max. tool diameter	mm	Ø80		
	Max. tool length	mm	200		
	Max. tool weight*	kg	3		
Motor	Spindle motor	kW	High torque type : 13/3.7 [Opt. 7.5/5.5] High efficiency type : 26/9 [Opt. 34/9]		
	X/Y/Z axis servo motor	kW	1.8/1.8/2.7 [Opt. 1.5/2.2/2.2]		3/3/3 [Opt. 2.2/2.2/2.2]
Machine size	Width×Depth×Height	mm	1,700×2,600×2,700	2,100×2,600×2,700	2,280×2,770×2,850
	Weight	kg	2,850	3,150	4,200
Controller			FANUC Oi-MF Plus [Opt. Mitsubishi M80VA]		

\*The max. tool weight is provided for reference. Different shapes and centers of gravity will influence the results.

©Specifications may be changed without prior notifications.